

# 70Z-Meter

Truck-Mounted Concrete Boom Pump

**Putzmeister**



70Z-Meter

- World's largest concrete boom pump
- 227' 4" (69.3m) vertical reach
- Complete Ergonic® capabilities
- Tight 59' (18.00m) turning radius
- One-Sided Support (OSS) system

# 70Z-Meter

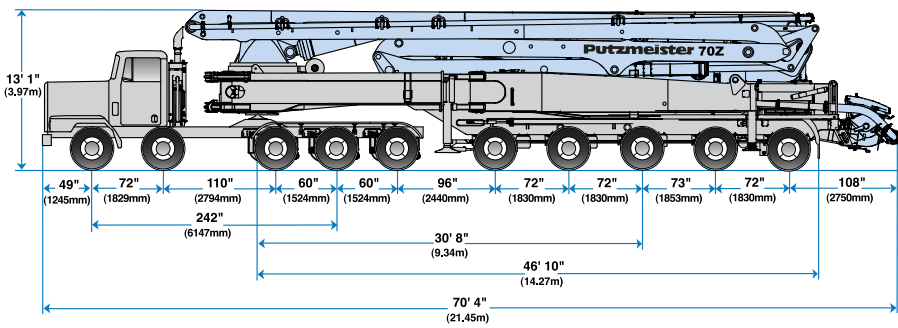

## Range Diagram

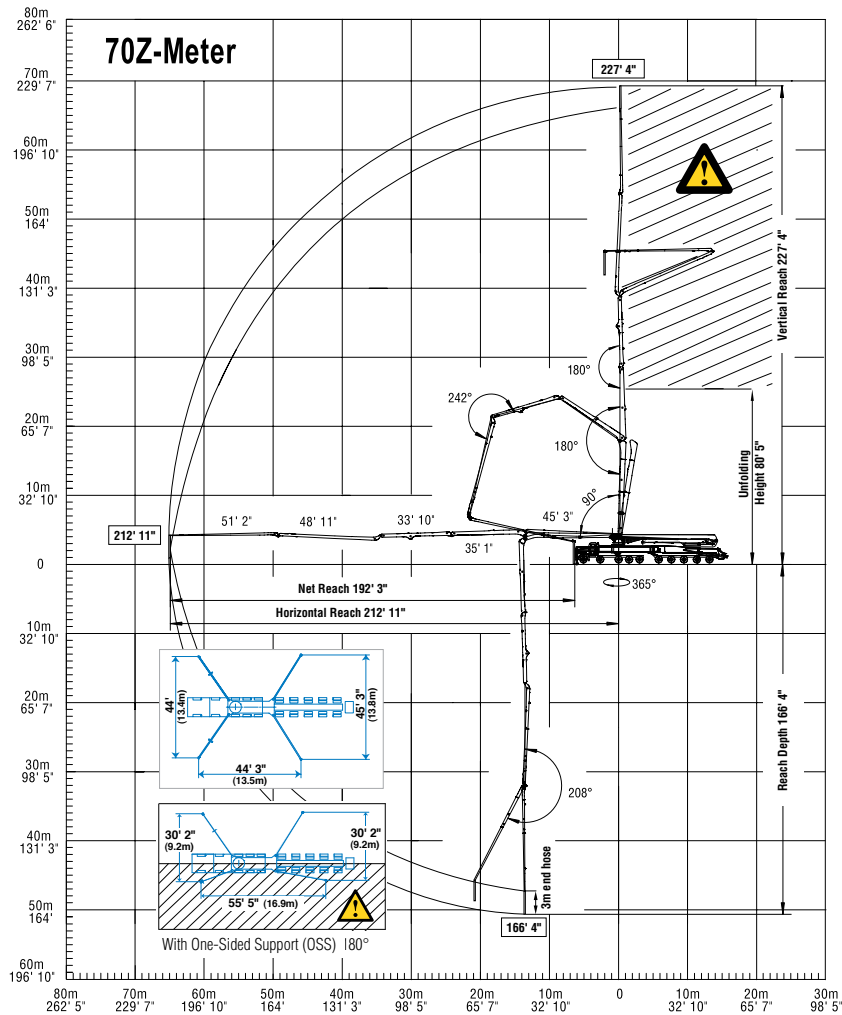

## Turning Radius

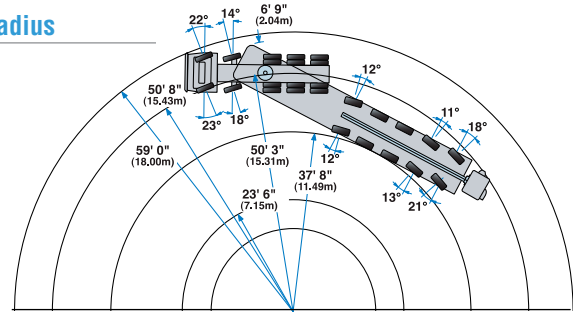

## 70Z-Meter Truck-Mounted Specifications

Based on Model Kenworth C500B with .16H pump cell

Length	70' 4"	(21.45m)
Width	8' 2"	(2.50m)
Height	13' 1"	(3.97m)
Wheelbase	242"	(6,147mm)
Front tractor axle weight	36,689 lbs	(16,642kg)
Tandem tractor axle weight	48,241 lbs	(21,882kg)
Rear trailer axle weight	91,000 lbs	(41,277kg)
Total tractor weight	84,930 lbs	(38,524kg)
Approx. total weight	175,932 lbs	(79,802kg)

Weights are approximate and include pump, boom, truck, full hydraulic oil, driver and some fuel. Varies with options selected.

Dimensions will vary with different truck makes, models and specifications.

## Boom Specifications • Z-Fold Design

<b>Height &amp; Reach</b>		
Vertical reach	227' 4"	(69.3m)
Horizontal reach	212' 11"	(64.9m)
Reach from front of truck*	192' 3"	(58.6m)
Reach depth	166' 4"	(50.7m)
Unfolding height	80' 5"	(24.5m)

<b>5-Section Boom</b>		
1st section articulation	90°	
2nd section articulation	180°	
3rd section articulation	180°	
4th section articulation	242°	
5th section articulation	208°	

1st section length	45' 3"	(13.8m)
2nd section length	35' 1"	(10.7m)
3rd section length	33' 10"	(10.3m)
4th section length	48' 11"	(14.9m)
5th section length	51' 2"	(15.6m)

<b>General Specs</b>		
Pipeline size (ID) metric ends	4.6"	(117mm)
Rotation	365°	
End hose — length (lightweight)	10'	(3m)
End hose — diameter	4.5"	(115mm)
Outrigger spread L - R — front swing out & telescope	44'	(13.4m)
Outrigger spread L - R — rear swing-out	45' 3"	(13.8m)

## Pump Specifications 70Z.16H

Output — rod side	210 yd <sup>3</sup> /hr (160m <sup>3</sup> /hr)
piston side	146 yd <sup>3</sup> /hr (112m <sup>3</sup> /hr)
Pressure — rod side	1233 psi (85 bar)
piston side	1885 psi (130 bar) •
Material cylinder diameter	9" (230mm)
Stroke length	83" (2100mm)
Max strokes per minute — rod side	31
piston side	21

Preliminary specifications. Consult factory for the most current information.

Maximum theoretical values listed.

\* Applies to units mounted on Model Kenworth C500B

• Standard delivery line system rated at max line pressure of 1233 psi (85 bar)

End hose not to be operated in caution area.

Photos and drawings are for illustrative purposes only. For available options, please refer to price list.



Putzmeister America, Inc. Telephone (262) 886-3200  
 1733 90th Street (800) 884-7210  
 Sturtevant, WI 53177 USA Facsimile (262) 884-6338  
 www.putzmeister.com



Authorized Distributor